

MT8

Mirror Image Technology Series



MT8 Three / MT8 Four
Owner's Manual

 **SpeakerCraft®**

Limited Lifetime Warranty



SpeakerCraft Inc. warrants to the original retail purchaser only that this SpeakerCraft product will be free from defects in materials and workmanship, provided the speaker was purchased from a SpeakerCraft Authorized Dealer. However, this warranty will automatically terminate if the original retail purchaser sells or otherwise transfers the product to any other party.

Defective products must be shipped, together with proof of purchase, prepaid insured to the SpeakerCraft Authorized Dealer from whom they were purchased, or to the SpeakerCraft factory at the address listed on this installation instruction manual. Freight collect shipments will be refused. It is preferable to ship these product in the original shipping container to lessen the chance of transit damage. In any case, the risk or loss or damage in transit is to be borne by the purchaser. If upon examination at the Factory or SpeakerCraft Authorized Dealer it is determined that the unit was defective in materials or workmanship at any time during this warranty period, SpeakerCraft or the SpeakerCraft Authorized Dealer will, at its option, repair or replace this product at no additional charge, except as set forth below. If this model is no longer available and can not be repaired effectively, SpeakerCraft, at its sole option may replace the unit with a current model of equal or greater value. In some cases where a new model is substituted, a modification to the mounting surface may be required. If mounting surface modification is required, SpeakerCraft assumes no responsibility or liability for such modification. All replaced parts and product become the property of SpeakerCraft Inc. Products replaced or repaired under this warranty will be returned to the original retail purchaser, within a reasonable time, freight prepaid.

This warranty does not include service or parts to repair damage caused by accident, disaster, misuse, abuse, negligence, inadequate packing or shipping procedures, commercial use, voltage inputs in excess of the rated maximum of the unit, or service, repair or modification of the product which has not been authorized or approved by SpeakerCraft. This warranty shall terminate if the serial number on the product has been removed, tampered with or defaced.

This warranty is in lieu of all other expressed warranties. If the product is defective in materials or workmanship as warranted above, the purchaser's sole remedy shall be repair or replacement as provided above. In no event will SpeakerCraft be liable for any incidental or consequential damages arising out of the use or inability to use the product, even if SpeakerCraft Inc. or a SpeakerCraft Inc. Authorized Dealer has been advised of the possibility of such damages, or for any claim by any other party. Some states do not allow the exclusion or limitation of consequential damages, so the above limitation and exclusion may not apply.

All implied warranties on the product are limited to the duration of this expressed warranty. Some states do not allow limitation on the length of an implied Warranty. If the original retail purchaser resides in such a state, this limitation does not apply.

CONTENTS

1. Getting Started	5
2. Speaker Placement	6
Single Pair of Speakers	6
Multiple Speakers for Home Theater	7
3. Installation Considerations.....	8
4. Installation Preparation – New Construction.....	9
5. Installation Preparation – Finished Wall	10
6. AcoustaCell® Installation.....	12
7. Speaker Installation	14
8. Painting the Speakers.....	15
9. Speaker Adjustments.....	16
10. Specifications	18
11. Customer Assistance	19

GETTING STARTED

Your MT8 Three or MT8 Four master carton contains the following items:

AcoustaCell® System Box:

- 2 Pieces, Center AcoustaCell® Chamber: 24"(H) x 14¾"(W) x 3½"(D)
- 4 AcoustaCell® Segments, 2 lower and 2 upper: 10"(H) x 14¾"(W) x 3½"(D)
- 2 Pieces, Center Wall Sheet: 20"(H) x 10"(W) x ½"(D)

MT8 Three or MT8 Four Speaker Box:

- 1 Right MT8 Speaker (The tweeter/midrange Uni-Pivot is on the right)
- 1 Left MT8 Speaker (The tweeter/midrange Uni-Pivot is on the left)
- 1 Cutout Template for MT8
- 2 Paint Masks for MT8

You may need the following tools when installing the MT8 speakers and AcoustaCell®:

- Stud finding tool
- Drywall Saw
- Screwdriver with #2 Phillips Head
- Pencil or Pen
- Level
- Wire Strippers
- Utility Knife
- Tape Measure

SPEAKER PLACEMENT

Single Pair

SpeakerCraft highly recommends the use of a qualified custom installation specialist when installing your MT8 speakers. If you need assistance in locating a dealer, please contact SpeakerCraft at 1-800-448-0976.

1. Determine Your Primary Listening Area

The area where you will most likely be sitting when listening to your speakers is your primary listening area.

2. Decide Distance Apart

Consider how far apart the speakers should be. To do this, think of your listening area as one tip of a triangle with each leg of the triangle being equal. (See Figure 1)

3. Decide Speaker Height

For optimum performance, the Uni-Pivot should be placed at or slightly above the listener's ear level. For conditions that do not allow the speaker to be put at the optimum height, please see "SPEAKER ADJUSTMENTS" on page 16.

4. Check for Obstructions

Before confirming the placement of your MT8 in-wall speakers and AcoustaCell® system, you should carefully consider the location of studs, fire blocks, electrical, plumbing and other fixtures that may get in the way. If you are installing the speakers into an existing wall, you can locate obstructions by noting the placement of wall fixtures and if possible gaining access to an attic or crawl space for further analysis. A good stud-finder, found at any building supply store, will help you determine where the studs are located in the wall.

If you are installing the AcoustaCell® Wall Dampening System with the MT8 speakers, you will need the following area within the wall cavity free of obstructions: 44" (H) x 14½" (W) x 3¾" (D). In some cases, the space may be too small to fit the entire AcoustaCell® System into an opening. If you find you don't have the necessary space, you may reduce the AcoustaCell® size by following the instructions under "ACOUSTACELL® INSTALLATION" on page 12. Please note that the AcoustaCell® is designed for installation into standard 2"x4" stud construction. If your installation is different, please contact your SpeakerCraft dealer for further assistance.

SPEAKER PLACEMENT

Multiple Speakers for Home Theater

The MT8 Three and MT8 Four speakers can be used in all five channels of a home theater system: main left and right, center, and rear left and right. (See Figure 2)

1. Placement of Front Channels

Follow the recommendations under speaker placement for “SPEAKER PLACEMENT —Single Pair” on Page 6.

2. Placement of Center Channel

For best results, a single speaker should be placed close to the screen, usually just above or below it. You may wish to mount the speaker horizontally. The Uni-Pivot can be pivoted 90° so that the tweeter and midrange will maintain their standard position. (See “SPEAKER ADJUSTMENTS” on page 16) If you are mounting the MT8 horizontally, the longest side down, you will need 20” of clearance left to right to mount the speaker. Standard 16” on center studs are too narrow.

3. Placement of Rear Channels

There are a number of options for using the MT8 as rear channels in a home theater. For optimum results, they should be placed behind the listener with the Uni-Pivot at ear level. It is usually desirable to diffuse the sound from the rear channels by pointing the Uni-Pivot in a direction away from the listener.

Figure 1

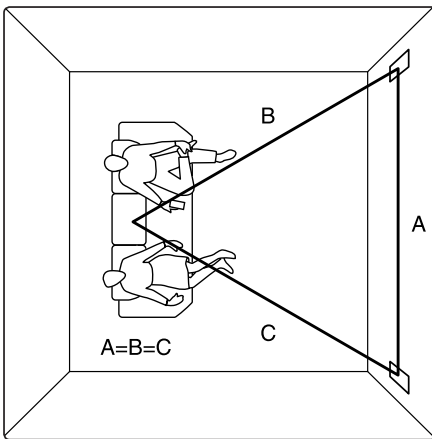
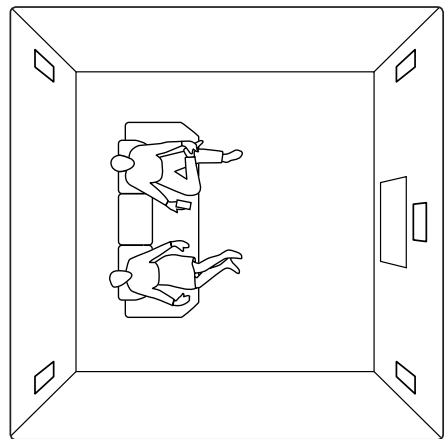

Figure 2



INSTALLATION CONSIDERATIONS

Prior to the actual installation of the speakers, it will be necessary to run cables to the speaker location. See your Authorized SpeakerCraft Dealer for more information on cable installation. After the cable has been installed, you are ready to mount the speakers.

Preparation for and mounting of the MT8 Three or MT8 Four and AcoustaCell® system can happen at two different stages. If you are building a new wall, follow the directions under “INSTALLATION PREPARATION — New Construction” on page 9. If you are placing the speakers into an existing wall, follow the directions under “INSTALLATION PREPARATION — Finished Walls” on page 10. There are different considerations for each application. Please follow the recommendations for your application carefully.

INSTALLATION PREPARATION

New Construction

When installing the MT8 into a newly built wall, please follow these instructions carefully:

1. Determine Placement

Determine where in the wall the speakers will be placed, using the recommendations under "SPEAKER PLACEMENT" on pages 6-7. Pay careful attention to the section on avoiding obstructions.

2. Mount InstaLock® Bracket

For best results, mount the SpeakerCraft InstaLock® New Construction Bracket for the MT8 (Part No. BKT90685) following the instructions included with the bracket. (See Figure 3)

3. AcoustaCell® Considerations

While mounting the AcoustaCell® system may be done at this time, it is not necessary. The system is designed to mount quickly and easily at the time of final speaker installation, using the instructions under "ACOUSTACELL® INSTALLATION" on page 12. The AcoustaCell® wings on the MT8 InstaLock® Bracket will assure that the AcoustaCell® fits exactly into place. AcoustaCell® should only be mounted at this time if there is an obstruction that would prevent the proper placement at the time of final installation.

4. The Location is Ready for Drywall

The bracket provides a stable opening around which the drywall installer can cut out an opening, providing a perfect location for installation of the MT8 and AcoustaCell® system. (See Figure 4)

5. Proceed to page 12, "ACOUSTACELL® INSTALLATION".

Figure 3

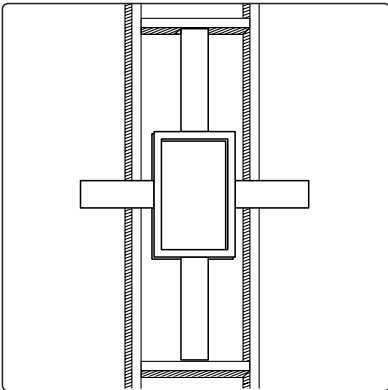
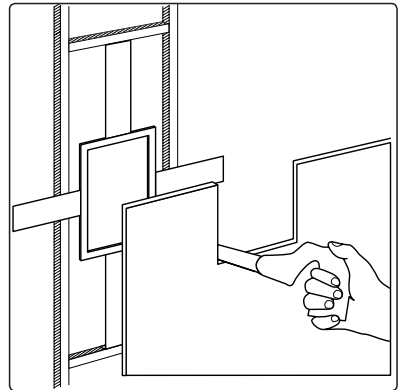

Figure 4



INSTALLATION PREPARATION

FINISHED WALL

When installing the MT8 into a finished wall, please follow these instructions carefully:

1. Determine Placement

Determine where in the wall the speakers will be placed, using the recommendations under "SPEAKER PLACEMENT" on pages 6-7. Pay careful attention to the section on avoiding obstructions.

2. Locate Obstructions

Find the studs nearest the desired speaker mounting location. The use of a good stud-finder tool is highly recommended for this procedure. The speakers should be centered between the two 16" on center studs. Make sure that there are no studs or obstructions where you plan to install the speaker. Read "Check for Obstructions" under the section "SPEAKER PLACEMENT" on page 6.

3. Trace Template

Place the cutout template at the location you have decided to place the speaker. Keep in mind that the flange of the speaker baffle will extend beyond the cut opening by $\frac{1}{8}$ ". Center the template between the studs. To aid in centering, the template width is 16". With the template in place, use a level along the top or bottom edge to make sure it is even with the floor and ceiling. Use a few pieces of tape or small tacks to hold the template in place. (See Figure 5) Trace an outline on the wall with a pencil.

Figure 5

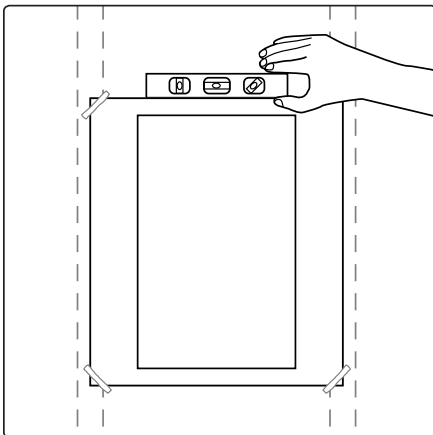
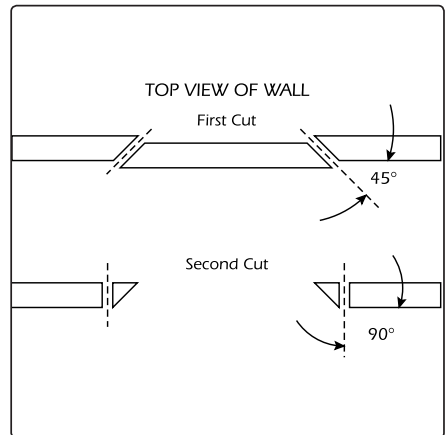

Figure 6



4. Cut the Hole

CAUTION: This is the most important part of the entire installation. If you are not certain whether or not an obstruction exist behind the desired mounting area, you should start by cutting a small hole in the center of your penciled mounting hole with a drywall saw. Cut at a 45° angle towards the inside of the hole. (See Figure 6) Cutting the small hole at this angle will make drywall repair much easier as the piece cut out can be installed neatly back into the hole. Once you have determined that there aren't any obstructions in your desired mounting location, start cutting the finished hole at a 90° angle to the wall surface.

5. Proceed to page 12, "ACOUSTACELL" INSTALLATION".

ACOUSTACELL™ INSTALLATION

The AcoustaCell® System is an integral part of the performance of the MT8. It dampens the wall cavity and improves the performance of the MT8. Installation can be easily done at the time you are ready to mount the MT8 speakers.

- 1.** Remove any insulation materials from the wall cavity so that there will be room for the AcoustaCell® System. Ideally you should have 44", centered top to bottom, clear for installation of AcoustaCell®. With the area cleared of insulation, you are now ready to install the AcoustaCell® System.
- 2.** Compress the lower AcoustaCell® segment so that it is small enough to fit through the opening (See Figure 7a) and place it down into the opening. If you have previously installed the MT8 InstaLock® New Construction Bracket, slowly push the AcoustaCell® down until it is stopped by the AcoustaCell® wing. If no bracket is in place, slowly move the AcoustaCell® down until with a rule you measure 5½" from the top of the AcoustaCell® to the bottom edge of the cut-out opening.
- 3.** Compress the upper AcoustaCell® segment and place it up into the opening. (See Figure 7a) If you have previously installed the MT8 InstaLock® New Construction Bracket, slowly push the AcoustaCell® up until it is stopped by the AcoustaCell® wing. If no bracket is in place, slowly move the AcoustaCell® up until with a rule you measure 3¾" from the bottom of the AcoustaCell® to the top edge of the cut-out opening.
- 4.** Compress the center chamber and place it into the opening so that it is caught between the upper and lower segments. (See Figure 7b)
- 5.** The last step is to place the center wall sheet into the chamber opening by removing the adhesive and placing against the back wall. (See Figure 7c)
- 6.** For best results, the speaker wire should be routed behind the AcoustaCell® and should enter the center AcoustaCell® chamber from directly above or below the chamber. (See Figure 8)
- 7.** You are now ready for installation of the MT8 speakers.

NOTE: In cases where the standard mounting configuration of AcoustaCell® is not practical because of fireblocks or other obstructions, it may be mounted in any configuration that the wall space permits. This may include mounting both shorter pieces above the center chamber or both of them below the center chamber. It may also include cutting the material down to fit into openings. To cut AcoustaCell®, place it flat on a surface and place a straight edge along the line you wish to cut. Use a sharp utility knife to cut through the material. After cutting half-way through, turn it over and repeat the process from the other side.

Figure 7a

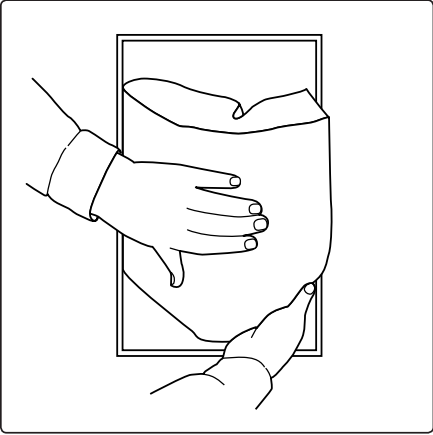

Figure 7b

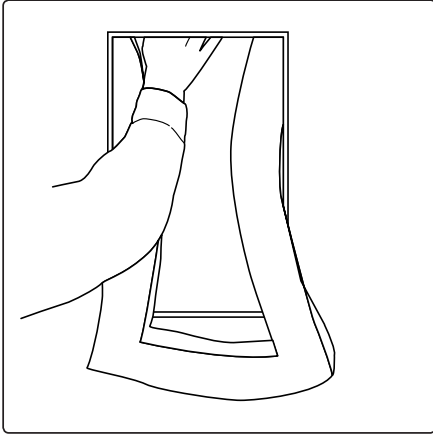

Figure 7c

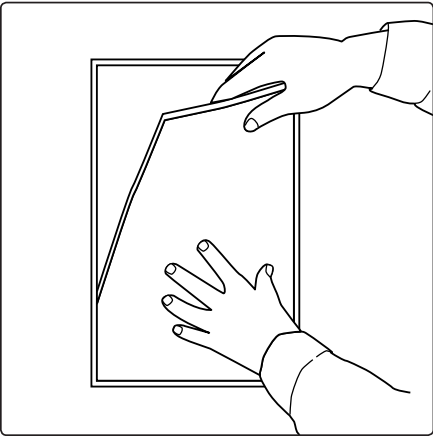
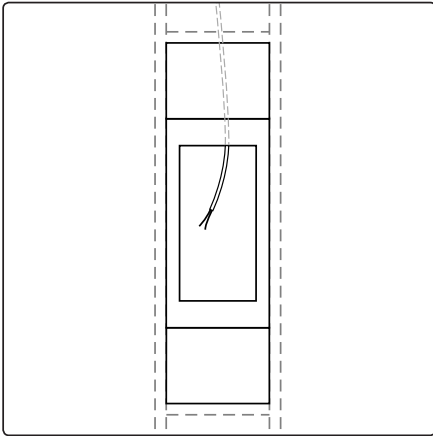

Figure 8



SPEAKER INSTALLATION

Note: Your MT8 Three or Four may have come with the optional Jawz[®] speaker wire connector. Before using Jawz[®], please follow the instructions included with the connector.

The unique I-Beam mounting system incorporated into the MT8 Three and MT8 Four allows for a quick installation by following these easy steps.

1. Remove the grille by pushing the two I-Beams, located at the rear of the speaker, towards the front of the speaker. The long screws attached to the I-Beams will force the grille off the baffle.
2. The MT8 speakers are mirror imaged. The Uni-Pivot is at the left edge of one baffle and the right edge of the other. When mounting in pairs, place the speakers so that the Uni-Pivots are at the inside of the pair.
3. Connect the speaker cable, observing the proper polarity with your amplifier (+ to + and - to -). Make sure the left channel of the amplifier is connected to the left speaker, and the right channel is connected to the right speaker.
4. Slide the top ends of the two I-Beams (at the woofer end of the speaker) up into the drywall opening until there is enough room at the bottom for the other ends of the I-Beams to clear the opening. Slide the bottom ends into the opening and position them behind the drywall. (See Figure 9)

Figure 9

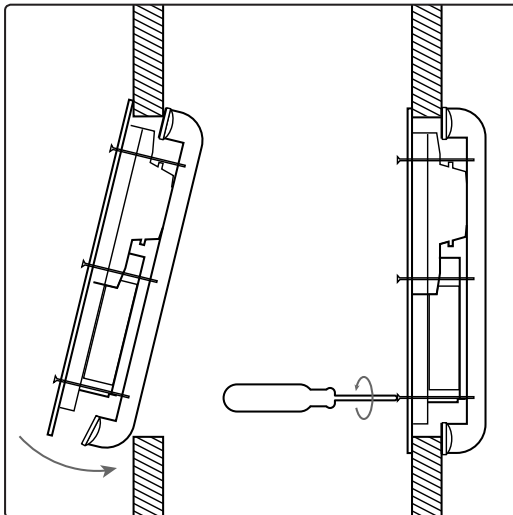

5. Position the speaker into the hole and start tightening the six screws evenly. This will allow the I-Beam bars to properly sandwich the drywall between the self adjusting I-Beam feet and the speaker flange. (See **Figure 9**) Make sure the speaker is positioned correctly before final tightening of the six mounting screws. **Note:** The flange of the speaker is designed to flex and conform to imperfections in the wall surface. **CAUTION: DON'T OVER-TIGHTEN THE SCREWS, PROCEED SLOWLY.** If the screws are tightened too much, the flange on the speaker may bow out. If this occurs, back off the tension on the screws until the bowing is eliminated.
6. Adjust the Uni-Pivot midrange/tweeter module to the desired position. (See "Adjusting the Uni-Pivot Module" on page 16)
7. Adjust the BASS and TREBLE switches to the desired position. (See "Adjusting the Frequency Response" on page 16)
8. Push the grille firmly into the slot in the speaker baffle.

PAINTING THE SPEAKERS

If you plan to paint your speakers, we recommend that it be done prior to installation. If you decide to paint your speakers sometime in the future, it is best to remove them by simply reversing the steps for "SPEAKER INSTALLATION" on pages 14-15. When painting the speakers, the paint masks provided in the carton must be installed in place of the grille. The grilles can also be painted, however, great care should be taken not to clog the holes, as this will greatly reduce the sound quality of the speakers. Before painting the grilles, remove the under grille material. Put this material back into place once the grille has been painted. SpeakerCraft recommends only light spray painting, using 5 parts thinning agent to 1 part paint. Do not paint grilles while they are attached to the speaker. If it is necessary to paint the under grille material, follow the same procedure used to paint the grilles.

SPEAKER ADJUSTMENTS

Adjusting the Uni-Pivot Module

The Uni-Pivot can be used to best direct the critical high frequencies towards the listener. The Uni-Pivot easily rotates and pivots to almost any position desired. (See Figure 10) Simply apply pressure with fingertips to the outer surface of the Uni-Pivot (See Figure 11) and rotate to the desired position. The Uni-Pivot should never be rotated more than 90° in a clockwise or counterclockwise direction.

- If the speakers are being used as main front channels, the Uni-Pivot should be angled towards the listener.
- If the speakers are being used for rear surround channels, you may wish to point the Uni-Pivot away from the listener to achieve a more diffused sound.
- If the MT8 is mounted horizontally, the Uni-Pivot can be rotated to stand in an upright position. (See Figure 12)

ADJUSTING THE FREQUENCY RESPONSE

The Mirror Image Technology Series speakers come from the factory with the Uni-Pivot midrange/tweeter module facing straight out from the baffle. This will result in the overall smoothest response. However, depending on your particular primary area, room acoustics, ceiling height, or personal preference, you may find the sound more pleasing by pointing the Uni-Pivot in a particular direction. If additional midrange and treble is desired in the primary listening area, point the Uni-Pivot towards that area; and if less midrange and treble is required, point the Uni-Pivot away. When used in a home theater surround sound environment as side or rear channel speakers, the best result will be obtained by pointing the Uni-Pivot toward an adjacent wall. Push gently at the edge of the Uni-Pivot to point it in the desired direction. (See Figure 11)

Treble Adjustment:

The three vertical buttons with the center button labeled “T” allow for 6dB of TREBLE (high frequency) adjustment. Your speakers were shipped with the treble set to neutral. This setting provides the most linear frequency response. If you desire more treble, push the button with the up arrow and the treble will play 3dB higher. If you want less treble, push the button with the down arrow and the tweeter will play 3dB lower. To return to the neutral setting, push the “T” button. (See Figure 13)

Midrange Adjustment:

The three vertical buttons with the center button labeled “M” allow for 6dB of MIDRANGE (middle frequency) adjustment. Your speakers were shipped with the midrange set to neutral. This setting provides the most linear frequency response. If you desire more midrange, push the button with the up arrow and the midrange will play 3dB higher. If you want less midrange, push the button with the down arrow and the midrange will play 3dB lower. To return to the neutral setting, push the “M” button. (See Figure 13)

Bass Adjustment:

The three vertical buttons with the center button labeled "B" allow for 6dB of BASS (low frequency) adjustment. Your speakers were shipped with the bass set to neutral, resulting in 6ohms of impedance. This setting provides the flattest bass frequency response. If you desire more bass, push the button with the up arrow and the bass will play 3dB higher and lower the impedance to 4ohms. If you want less bass, push the button with the down arrow and the bass will play 3dB lower and increase the impedance to 8ohms. This setting provides a more linear bass frequency response. To return to the neutral setting, push the "B" button. (See Figure 13) Remember that altering the impedance affects the number of speakers able to be driven by an amplifier. If multiple pairs of speakers are to be driven by one amplifier, SpeakerCraft suggests using the lowest output position (the down arrow) until it is determined that the amplifier will operate properly with the speakers switched to a higher output mode. If you want to safely operate multiple pairs of speakers, consider purchasing SpeakerCraft S4 or S8 Speaker Selectors.

Figure 10

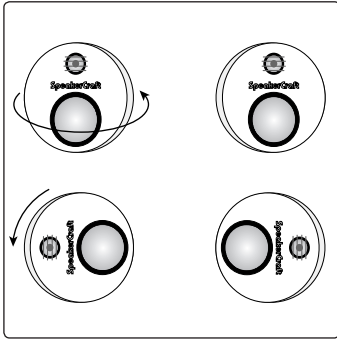

Figure 11



Figure 12

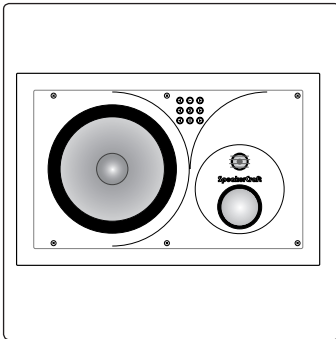
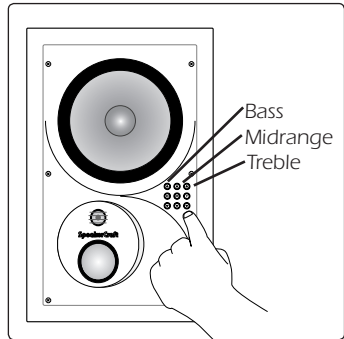

Figure 13



IMPORTANT NOTICE

Please read before installation

The desired setting for treble, midrange and bass MUST be pressed in order for the speaker to play properly. The tweeter will NOT play if a selection is not made.

MT8 THREE SPEAKER SPECIFICATIONS

Speaker Type:	3-Way In-Wall
Woofer:	8" Aluminum Cone
Midrange:	2½" Aluminum Dome Uni-Pivot
Tweeter:	1" Aluminum Dome Uni-Pivot
Impedance:	8/6/4 Ohms Depending on Button Settings
Sensitivity:	90dB 1W/1m
Frequency Adjustments:	Front-Mounted 3 Position ±3dB Bass, Midrange and Treble Adjustment Buttons
Frequency Response:	39Hz - 20kHz ± 2dB
Power Recommendations:	5-200 watts (undistorted)
Dimensions:	16½" (H) x 10½" (W) x 3¾" (D)
Wall Cut Out:	15½" (H) x 9½" (W)

In our attempt to constantly improve our products, features and specifications are subject to change without notice

MT8 FOUR SPEAKER SPECIFICATIONS

Speaker Type:	3-Way In-Wall
Woofers:	8" Aluminum / Magnesium Cone with Phasing Dome
Midrange:	2½" Aluminum / Magnesium Dome Uni-Pivot
Tweeter:	1" Aluminum / Magnesium Dome Uni-Pivot
Impedance:	8/6/4 Ohms Depending on Button Settings
Sensitivity:	90dB 1W/1m
Frequency Adjustments:	Front-Mounted 3 Position ±3dB Bass, Midrange and Treble Adjustment Buttons
Frequency Response:	38Hz - 20kHz ± 2dB
Power Recommendations:	5-200 watts (undistorted)
Dimensions:	16½"(H) x 10½"(W) x 3¾"(D)
Wall Cut Out:	15½"(H) x 9½"(W)

In our attempt to constantly improve our products, features and specifications are subject to change without notice

CUSTOMER ASSISTANCE

If you have any questions regarding the MT8 Three, MT8 Four or any other SpeakerCraft product, please contact your local Authorized SpeakerCraft dealer, or you may contact SpeakerCraft toll-free at 1-800-448-0976 for immediate customer assistance. We are available to assist you every weekday, except holidays, between the hours of 7:00 a.m. and 5:00 p.m. PST.

940 Columbia Ave., Riverside CA 92507-4492
(800) 448-0976, Fax (951) 787-8747
www.speakercraft.com



LIT87802