

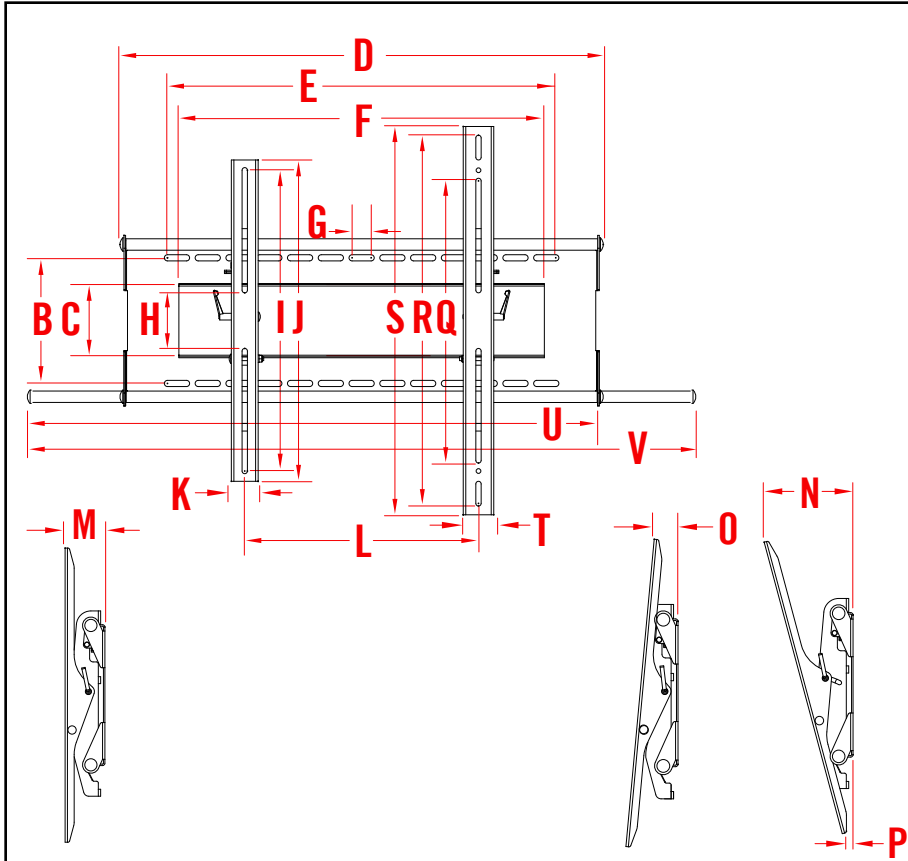

# U3-T

## LARGE UNIVERSAL TILT MOUNT



TECHNICAL SPECIFICATIONS		
A	11.25"	285.75mm
B	8.25"	209.55mm
C	4.40"	111.76mm
D	31.75"	806.45mm
E	25.50"	648.00mm
F	24.00"	609.60mm
G	1.25"	31.75mm
H	3.94"	100.00mm
I	19.75"	501.65mm
J	21.13"	536.70mm
K	1.75"	44.45mm
L	2.75-28.25"	69.90-717.60mm
M	2.89"	73.41mm
N	6.00"	152.40mm
O	2.00"	50.80mm
P	1.00"	25.40mm
Q	18.25"	463.55mm
R	24.00"	609.60mm
S	25.50"	647.70mm
T	2.00"	50.80mm
U	37.75"	958.85mm
V	43.75"	1111.25mm



**Fast & easy low profile tilt mount with Lift-and-Lock installation**

- Tilt (+15° to -5°) and sliding lateral on-wall adjustment
- Double stud wall plate: max 25.5" (648mm) stud separation
- Includes mounting guide, locking system and complete mounting hardware kit
- VESA compliant 75 to 200x200
- Available in silver and black
- 200 lb. (90.7 kg) maximum weight capacity

